



MONACO®

MESSAGE CENTER

Addendum

Diplomat 2008

The information printed here reflects product design, fabrication, and component parts at the date of printing. The manufacturer reserves the right, at any time, to make changes in product design or material or component specifications as its sole option, without notice. This includes the substitution of components of a different brand or trade name, which will result in comparable performance. All information printed in this document is subject to change after the date of printing. Due to product improvements, changes during the model year and/or transcription errors that may occur, information represented within the owner's manual and/or this document may not be accurate at the time of your purchase. Please confirm any information with your dealer.

The following information supercedes previous information and applies to all motorhomes equipped with a Roadmaster Chassis.

©Monaco Coach Corporation. All rights reserved. All other trademarks or registered trademarks are property of their respective holders. Brand name products of other companies mentioned in this addendum are not endorsed by Monaco Coach Corporation.

The following information applies to the 2008 Monaco Diplomat. A Message Center option replaced the existing Instrument Panel and Gauges beginning with Unit Number 177045. This information replaces the current information in Section 9, pages 181-183.

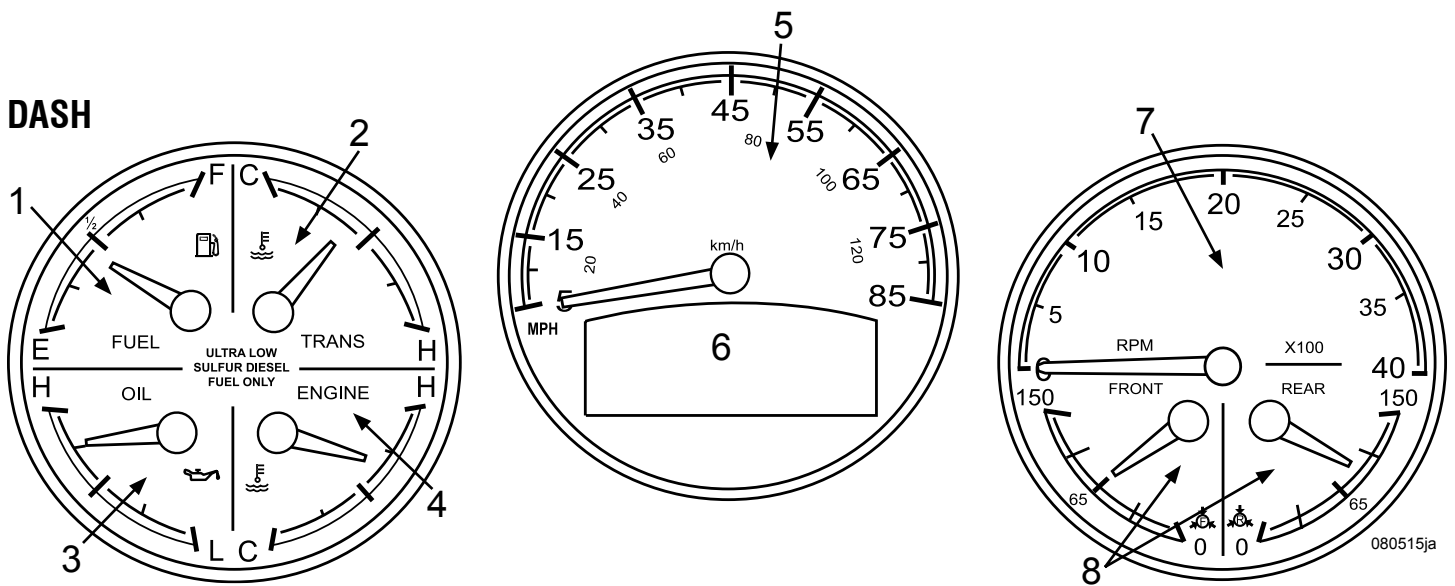

Gauges

- 1. FUEL:** The fuel gauge will register approximate fuel tank level when the ignition switch is in the run position.

NOTE:

Fuel mileage varies with driving style and road conditions. Always average more than one tank of fuel to obtain a more accurate figure. The diesel generator and the optional Aqua-Hot system both use fuel from the main tank and will affect fuel mileage figures. Diesel generators and Aqua-Hot will not operate below 1/4 tank to ensure there is enough fuel to run the engine.

- 2. TRANS TEMP:** Shows approximate temperature of the transmission fluid. DO NOT let the transmission oil temperature exceed OEM specifications. Stop the motorhome and shift into neutral if excess temperature is indicated. Idle the engine at 1200 to 1500 RPM and allow transmission fluid temperature to return to normal.
- 3. OIL PRESSURE:** Indicates oil pressure (not the amount of oil in the engine). Refer to OEM engine manual for specific pressure recommendations.
- 4. COOLANT TEMPERATURE:** Indicates an approximate normal operating range. Monitor this gauge frequently in all conditions, especially when climbing hills, towing and/or traveling in high ambient temperatures. If the needle reaches an out of range condition, take immediate action to avoid engine damage. Refer to the OEM instructions for specific temperature recommendations.
- 5. SPEEDOMETER:** Indicates the speed of the motorhome in MPH and KPH.
- 6. ODOMETER:** Displays total mileage.
- 7. TACHOMETER:** Displays engine speed in revolutions per minute (RPM).

8. AIR PRESSURE GAUGES: One gauge is for the front air tank; the other is for the rear air tank.

Normal air system operating pressures are approximately 115 to 145 psi. These air pressures are preset at the factory. If a problem occurs with either air system not maintaining normal operating pressure, there is a malfunction in the air system. Use caution and stop the motorhome in a safe area. Contact an authorized service technician immediately.

NOTE:

It is not safe to drive the motorhome with low air pressure. Damage can occur to the suspension and driveline and also affect operation of the air brake system.

Indicator Lights

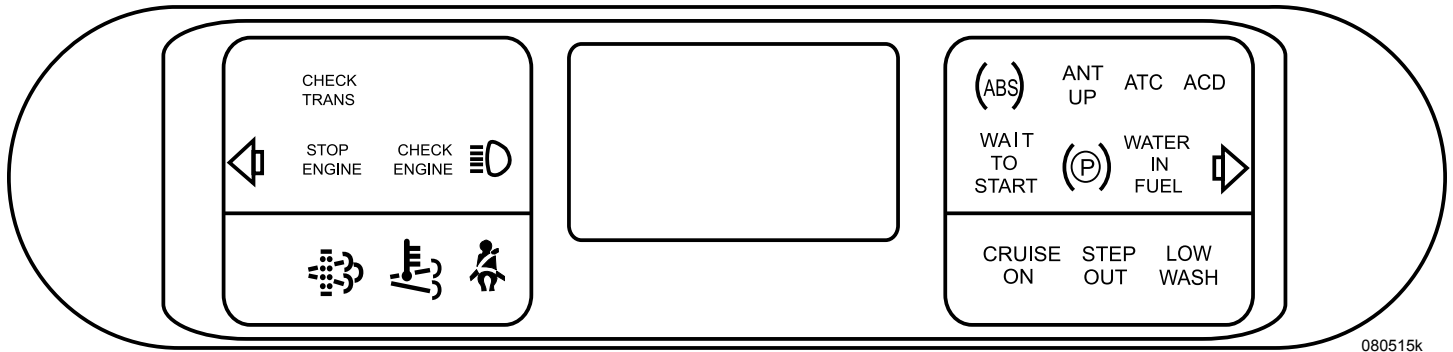

Message Center

LEFT ARROW - Audible Turn Indicators: Left turn indicator circuits active. Alarm sounds when active.

CHECK TRANS:

Alerts of problems related to the Allison Transmission. The light should momentarily illuminate when the ignition is switched ON. When starting, the lamp will extinguish, indicating the circuits are working properly. If the lamp fails to illuminate or remains on, the transmission needs to be checked immediately. Contact the nearest authorized Allison service center.

STOP ENGINE:

A severe out of range condition exists within the engine protection circuits. Pull over and stop as soon as possible. Shut-off the engine to avoid damage to the engine or related systems.

CHECK ENGINE:

An out of range condition exists within the engine protection circuits. Have the motorhome serviced as soon as possible.

HIGH BEAM:

High beams are active.

DPF:

The DPF (Diesel Particulate Filter) light signals an active regeneration cycle is necessary, but unable to initiate.

HEST:

The HEST (High Exhaust System Temperature) light illuminates when an active regeneration cycle is underway and exhaust temperatures are elevated. No fault exists as long as there are no other active warning lights.

SEATBELT LIGHT:

Alarm sounds and indicator stays lit for eight seconds after the key is turned on.

ABS:

Indicates possible fault in the ABS Brake system.

ANTENNA UP:

Illuminates when the TV antenna is raised. Lower the antenna before moving the motorhome.

ATC:

The ATC (Automatic Traction Control) light is continuously lit when ignition is first turned on and stays lit until the brakes are used for the first time and then turns off. The ATC light will flash continuously when the ATC switch (located on the driver console) is on.

ACD:

Not Used.

WAIT TO START:

Indicates the pre-heat cycle is active. Wait for indicator to cycle off before starting the engine.

PARK BRAKE:

Parking/emergency brake is applied.

WATER IN FUEL:

Water has been detected in the primary fuel filter. Purge water from primary filter at engine compartment.

RIGHT ARROW - Audible Turn Indicators:

Right turn indicator circuit is active. Turn alarm sounds when active.

CRUISE ON:

Cruise control is activated.

STEP OUT:

Not Used

LOW WASH:

Indicates low windshield washer fluid.

LCD DISPLAY:

The LCD displays chassis data and fault codes. A ten button LCD controller is to navigate the system. Press the up and down arrows to scroll through menus. Press the enter button to select items.



LCD CONTROLLER:

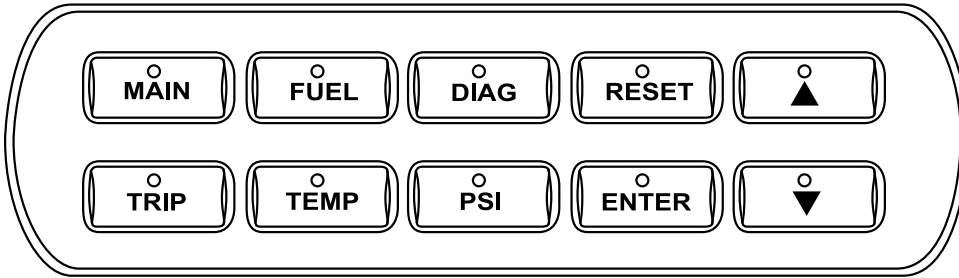

080515F

LCD Screen

080515k

MAIN – Press to return to the main screen. The main screen displays outside temperature, chassis battery voltage and odometer.

FUEL – Press to display average miles per gallon, instantaneous miles per gallon, and fuel used. Hold the reset button for five seconds to clear.

DIAG – Press to view engine, transmission, ABS, and LCD diagnostic menu. Use the up and down arrow to highlight an option. Press Enter to view diagnostic information and options.

RESET – Press and hold for five seconds to clear selected trip information (trips 1 through 4 can be individually selected for reset).

TRIP – Press to view Trip menu. Use the up or down arrow to highlight a trip, and press Enter to view trip information. Trip information includes average speed, distance traveled, trip time and fuel used.

TEMP – Press to view outside, basement, transmission and engine coolant temperature.

PSI – Press to view oil pressure, turbo boost pressure and front and rear air tank PSI.

ENTER – Press to select Menu items.

The LCD also displays the following warnings:

- ◆ Eng Comm Failure
- ◆ ABS Comm Failure
- ◆ Trans Comm Failure
- ◆ Check Engine
- ◆ Check Transmission
- ◆ Low Oil Pressure
- ◆ High Trans Temp
- ◆ High Coolant Temp
- ◆ Low/High Battery
- ◆ Low Air Pressure – Front
- ◆ Low Air Pressure – Rear
- ◆ Low Fuel Level
- ◆ Engine Not Running
- ◆ Low Coolant Level
- ◆ Alt Fail
- ◆ Turn Signal - For “Turn Signal” to display, the turn signal must be active for one mile before warning appears.

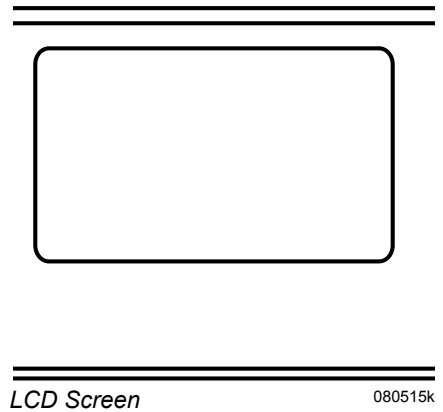

How to Adjust Screen Contrast:

1. Press DIAG button on LCD Controller.
2. Arrow down to 4 - Ins. Diag. Press enter.
3. Arrow down to 5 - Contrast. Press enter.
4. Use arrow buttons to select value desired. 40 is the default value.
5. Press MAIN button on LCD Controller to exit.

NOTE:

Layouts may vary with difference in models or options.

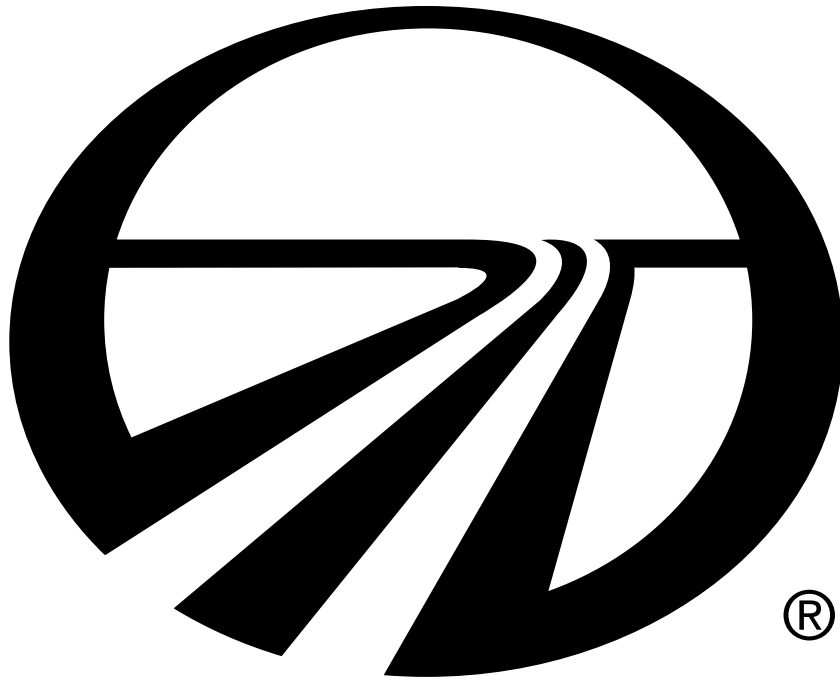

M O N A C O ®

Monaco Coach Corporation
91320 Coburg Industrial Way
Coburg, OR 97408
800-634-0855
www.holiday Rambler.com

Warranty/Technical Support
Toll Free 877-466-6226